

KENT
Mineral RO™
 Water Purifiers
 HOUSE of PURITY



Marketed by:
KENT RO SYSTEMS LTD.
 E-6, 7 & 8, Sector-59, Noida, U.P.-201 309, India.
 E-mail: sales@kent.co.in | Website: www.kent.co.in

Manufactured by:
KENT RO SYSTEMS LTD.
 1) Khasra No. 93, Village-Bantakhedi, Tehsil-Roorkee, District-Haridwar, Uttarakhand-247 668, India.
 2) A-6, Sector-87, Noida-201305, U.P., India.

For customer complaints, contact our Customer Care Officer at:
 E-6, 7 & 8, Sector-59, Noida, U.P.-201 309, India. Call: 92-789-12345
 E-mail: service@kent.co.in or visit us at www.kent.co.in

KENT WONDER

Wall-mounted/Table-top
 Detachable Tank
 RO Water Purifier

KENT
Mineral RO™
 Water Purifiers
 HOUSE of PURITY

Instructions Handbook



Mineral RO™ TECHNOLOGY

Removes Dissolved Impurities
 Retains Essential Minerals
 Multiple Purification

RO + UF + TDS Control

Kent Deta Hai
Sabse
Shudh Paani

Mineral RO™ © 2005 KENT RO Systems Limited.

The process and the purifier is patented vide a Patent No. 199716



Welcome to KENT

Dear Customer,

Welcome to the world of KENT, leaders of water purification industry in India. With a KENT product you have all the reasons to smile, because at KENT we take pride in the quality and laboratory-tested performance of our products.

We are confident that your decision to own KENT Wonder Mineral RO™ Water Purifier will go a long way in serving you with purer and mineral enriched drinking water, thus keeping you and your family in good health. We assure you that you will be satisfied with its trouble-free performance and quality which comes without any compromise.

This manual is an effort towards familiarising you with the operation and maintenance of KENT Wonder Mineral RO™ Water Purifier. Before operating the unit, please read it thoroughly and retain it for future reference. To ensure that the warranty of your water purifier is effective, fill up the enclosed warranty card and send the installation report within 15 days of purchase. Should you need further assistance, do not hesitate to contact your nearest KENT dealer or branch.

Best Wishes,

KENT RO SYSTEMS LTD.

Table of Contents

1.	KENT TECHNOLOGY - A Breakthrough in Water Purification	1
2.	Salient Features	1
3.	Items in the Box	1
4.	Important Instructions	2
5.	Reverse Osmosis Process	3
6.	UF Process	3
7.	Water Flow Diagram	4
8.	Electrical Circuit Diagram	4
9.	Automatic Operation	5
10.	Installation Instructions	5
11.	TDS Adjustment	6
12.	Starting-up the Purifier	7
13.	Recommended Usage of Rejected Water	7
14.	Maintenance	7
15.	Important Safety Instructions	7
16.	Cleaning the Water Tank	8
17.	Technical Specifications	9
18.	Testing Information	9

KENT TECHNOLOGY - A Breakthrough in Water Purification*

KENT proudly presents KENT Wonder Mineral RO™ Water Purifier- its new and advanced domestic water purifier which provides purer & healthier drinking water.

The futuristic KENT Wonder Mineral RO™ Water Purifier, developed at KENT laboratory broadly comprises of state-of-the-art RO+UF+TDS Control System. The initial purification by RO membrane having porosity as fine as, 0001 microns reduces even the dissolved impurities (hard salts, heavy metals etc.). Double purification by UF membrane gives additional protection from harmful micro-organisms. Moreover, the patented TDS Control System intelligently retains essential natural minerals in purified water, thus taking total care of your health and well being.

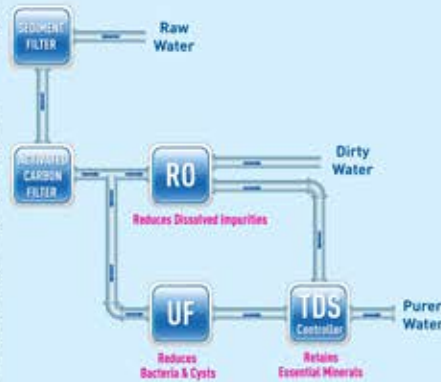

Salient Features of KENT Wonder Mineral RO™ Water Purifier

- Wall mounted/Table-top design - best suited for domestic purpose
- Double purification by RO+ UF process
- Adjustable TDS Control System allows adjustment of TDS level of purified water
- Transparent, detachable storage tank for easy onsite cleaning on regular basis
- 7 litre storage tank provides water on demand
- LED indicators for power and purification process status display
- Fully automatic operation with auto-on/off
- Tamper-proof RO and UF Membrane fused inside membrane housing
- Vertically mounted SMPS for protection
- Push-fit components for leak-proof & maintenance-free performance
- ABS construction for corrosion-free life span
- Suitable for purification of Brackish / Tap water / Municipal water supply

Items in the Box

1. KENT Wonder Mineral RO™ Water Purifier	:	01 No.
2. 3-Way Connector	:	01 No.
3. S.S. Ball Valve	:	01 No.
4. Screws & Plastic Inserts	:	02 Nos. each
5. Warranty Card	:	01 No.
6. Sticker Center Drill	:	01 No.
7. Food Grade Pipe ¼ inch (Blue)	:	2.5 m
8. Food Grade Pipe ⅜ inch (White)	:	2.5 m

Important Instructions

<p>Avoid exposure to direct sunlight and installation in damp areas.</p>	<p>Make sure that the purifier is connected to normal temperature water supply only.</p>
<p>Make sure that the rejected water pipe is not placed at a level higher than the purifier, otherwise rejected water may flow backwards into the purifier.</p>	<p>Maximum distance between the water source and purifier should not be more than 3 mtrs.</p>
<p>Avoid sharp bends in pipes.</p>	<p>Do not confine the purifier in a cabinet.</p>
<p>In case of not using the purifier for more than two days, kindly switch off the power supply and drain out the storage tank.</p>	<p>To keep the storage tank clean, it should be removed, cleaned and wiped once in 15 days.</p>
<p>Use Genuine Kent spares for optimum performance.</p>	<p>Do not try to service the purifier on your own. Instead, call service technician for help.</p>

* Tested & Certified by TUV-SUD South Asia (P) Ltd.

Reverse Osmosis Process

Reverse Osmosis process, also known as hyper filtration, is the finest filtration process known till date. It ensures reduction of particles as small as ions from a solution. Reverse Osmosis process uses a semi-permeable membrane to reduce salts from potable/brackish water. In Reverse Osmosis, water pressure is applied to the inlet impure water resulting in squeezing of pure water from the concentrated end of membrane towards the diluted end.

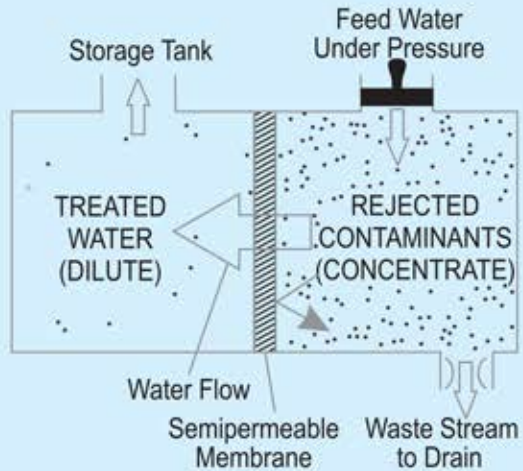

Dissolved salts present in water as charged ions, get repelled by the RO membrane and are not allowed to pass through. Similarly, bacteria and germs are also blocked by the ultra fine pores of RO membrane. These rejected impurities suspended on the concentrated end of the membrane are washed away in a stream of waste water, preventing the membrane from clogging.

UF Process

Ultra Filtration is a separation process that uses membranes with pore sizes of 0.01 micron. UF membranes reduce high molecular-weight substances, colloidal materials, and organic and inorganic polymeric molecules including bacteria and viruses. Low applied pressures are therefore sufficient to achieve high flux rates from an Ultra Filtration membrane.

Water Flow Diagram

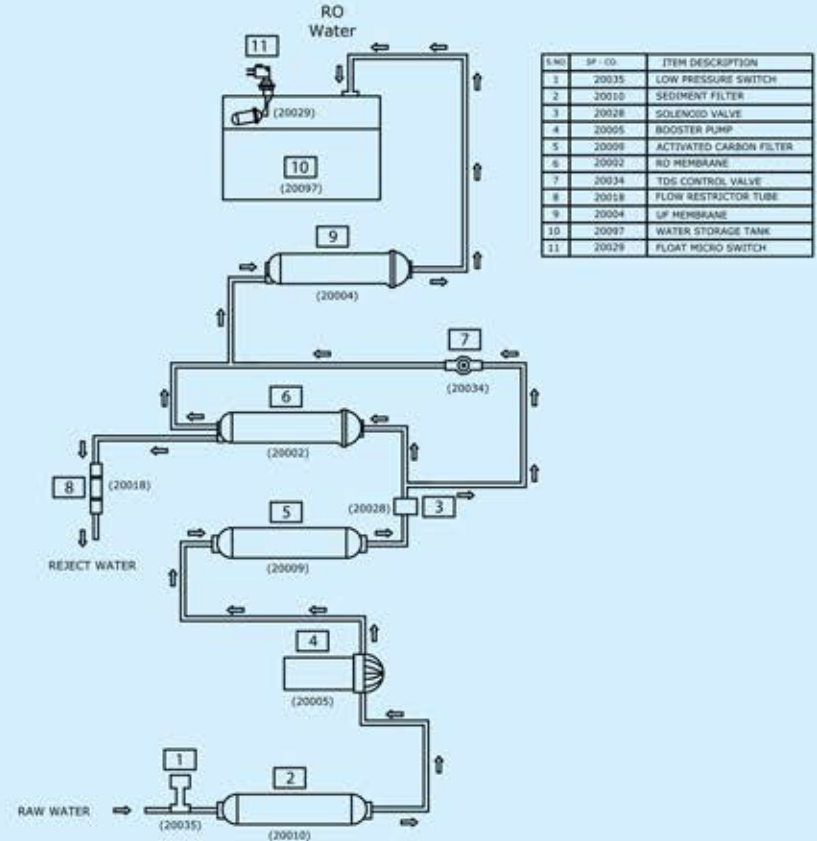

[NOTE: The above specifications are subject to modifications for improvement without notice.]

Electrical Circuit Diagram

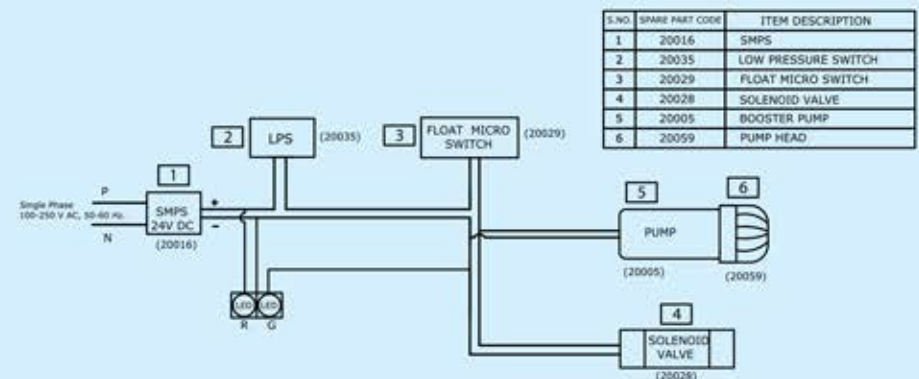

Automatic Operation

- The purifier automatically shuts off when the storage tank is full
- The purifier does not start when inlet water supply pressure is below 0.3 kg/cm²
- The purifier automatically restarts when water level drops below the maximum
- The purifier does not allow any water rejection in absence of electricity / when tank is full

Installation Instructions

KENT Wonder Mineral RO™ Water Purifier is a convenient and easy-to-install Wall-mounting / Table-top model.

Recommended Site Preparations

- Single Phase 100-250 V AC 50-60Hz. supply not more than 3 m away from the point of installation
- Raw water supply with 1/2 inch nipple, not more than 3 m away
- Drain for reject water, not more than 3 m away
- Installation space as per the dimensions of the purifier
- For optimum inlet pressure, source water tank should be installed at least 10 ft above the purifier
- Install the purifier near a sink for easy availability of inlet and reject water lines
- The system and installation need to comply with state and local laws and regulations

Installation Procedure

Step-1

Wall Hanging Diagram

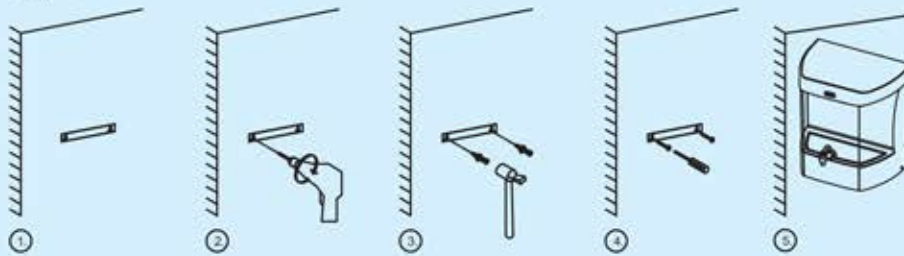

1. Paste the central drill sticker on the wall at (3.6 Feet to 4.0 Feet from the ground) as per your convenience.
2. Ensure that the sticker is pasted straight on the wall, then drill holes as per the space provided on sticker.
3. Now, insert the puff up with the help of a hammer.
4. Screw in two 10X50 self-taping screws, 5.4 inches (138 mm) apart horizontally.
5. Carefully hang the purifier on the wall with the help of wall-mounting slot holes provided on back side of the purifier.

Note:

1. If the wall is not straight or the screws are not properly drilled in an even position, it will damage your purifier.
2. Keep the device away from heat or direct sunlight.

Step-2



1. First, fix the SS ball valve (marked as no. 4) to the 1/4 inch port of the 3-way connector (marked as no. 2) as shown in figure 2.
2. Connect the 3-way connector to the raw water supply (marked as no. 1) as shown in the figure 3. The 3-way connector is fitted in line with the raw water supply.
3. The other end of the 3-way connector can be connected to a tap (marked as no.3) as shown in figure 4. or can be plugged off if not required.

Step-3

1. Now connect one end of the white pipe to SS ball valve and another end to the upper push-fit elbow fitting to the left hand side of the purifier labelled as WATER IN, as shown in fig 1.
2. Similarly, connect one end of the white pipe to the lower elbow fitting connector in tank labelled as REJECT WATER and leave the other end in the drain, as shown in fig 2.

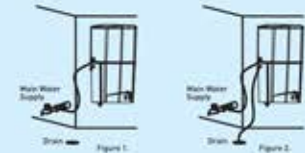

Step-4

Before connecting the power supply, it is important that you perform the following functions:

1. Open the SS ball valve (handle parallel to the ball valve) to start the flow of water into the purifier, as shown in the figure.
2. Wait for 2-3 minutes to ensure that the filters are soaked in water.

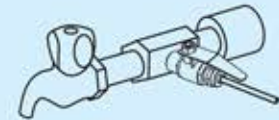

Step-5

1. Connect the power supply.
2. Installation is complete.

TDS Adjustment*

The unique TDS Controller enables customers to retain the contents of natural minerals in purified water, as per their requirement.

- Turning the screw of the valve anti-clockwise, results in an increased mineral content
- Turning the screw of the valve clockwise, results in a decreased mineral content

We recommend keeping the TDS at the lowest possible level but not below 50mg/l.

* Tested & Certified by TUV-SUD South Asia (P) Ltd.

Starting-up the Purifier

- Switch on the power supply
- Allow the storage tank to fill till the maximum level**
- Switch off the power supply
- Open the upper cover, lift and drain the storage tank to remove residual dust particles present inside the pipe and storage tank
- Place back the storage tank and close the upper cover
- Switch on the power supply
- Purifier is ready to use

 The glowing Red LED indicates that the power is ON. The glowing Green LED indicates that the purification process is ON.

Recommended Usage of Rejected Water

Although the rejected water has high concentration of salts, it is absolutely clean and free from impurities like chlorine, dirt, sand, etc. This rejected water usually goes down the drain, but it can be used for gardening purposes.

The high concentration of salts and minerals accelerate plant growth. Rejected water can also be used for cleaning utensils, mopping, etc.

Maintenance

To ensure that the purifier operates at its BEST, a routine maintenance must be performed. The frequency of the maintenance will greatly depend upon the raw water quality and consumption of purified water.

- Storage tank must be cleaned once in a week (Refer Cleaning the Water Tank)
- Replace sediment filter and activated carbon filter once in 12 months or earlier if they get clogged. It is recommended to change the FRT along with the filters
- Replace RO membrane once in a year or earlier if it gets clogged
- Replace UF membrane once in a year or earlier if it gets clogged
- In the event of not using purifier for a long time (while going for a holiday, tour, etc.), ensure that you disconnect the power supply, turn off the raw water supply and drain out the storage tank

Important Safety Instructions

- If the supply cord is damaged, it must be replaced by manufacturer, its service agent or similarly qualified persons in order to avoid a hazard.
- Children should be supervised to ensure that they do not play with the appliance.
- The appliance is not intended for use by person (including children) with reduced physical, sensory or mental capabilities, or lack of experience and knowledge, unless they have been given supervision or instruction concerning use of the appliance by a person responsible for their safety.

** Tested or certified flushing time - 24hrs.

Cleaning the Water Tank



Note: Filters and membrane are consumables. Their replacement time depends upon the quality of raw water and water consumption. They are not covered under the warranty. However, if a filter chokes within six months and a membrane within a year, it will be cleaned/repared/replaced free of cost. Changing the filters and system inspection is available on call. The purification capacity of RO membrane will reduce with time due to clogging of pores of membranes.

The Reverse Osmosis System contains a replaceable treatment component critical for the effective reduction of total dissolved solids and that product water shall be tested periodically to verify that the system is performing properly.

Replacement of spare parts are as under:-

-20010	SP Inline Sediment Filter 8"
-20009	SP Inline Carbon Filter 8"
-20002	SP RO Membrane Welded 8" Housing
-20004	SP UF Membrane Welded 8" Housing
-20018	SP FRT 550/600

"This Reverse Osmosis System contains a replaceable component critical to the efficiency of the system. Replacement of the reverse osmosis component should be with one of identical specifications as defined by the manufacturer, to ensure the same efficiency and contaminant reduction performance."

Technical Specifications

Product	KENT Wonder
Product Code	11033
Product Generic Name	Water Purifier
Product Colour	White
Applications	Suitable for Purification of Brackish/ Tap Water/Municipal Corporation Water
Purification Production Rate	15 L/hr.
Body Material	ABS Food Grade Plastic
Mounting	Wall-mounting/Table-Top
Dimensions(mm)	390 (L) x 285 (W) x 440 (H)
Inlet Water Pressure/Temp (Min.)	0.3 kg/cm ² /10°C
Inlet Water Pressure/Temp (Max.)	4 kg/cm ² /40°C
Min/Max Operating pH	6.5-8.0
Filter Cartridge	Sediment, Activated Carbon, UF
UF Membrane	0.01 - 0.1 microns
Membrane Type	Thin Film Composite RO
Net Weight	7.70 kg
Storage Capacity	7 L
Maximum Duty Cycle	75 L/day
Booster Pump Voltage	24 V DC
Total Power Consumption	60 W
Input Power Supply	Single Phase 100-250 V AC, 50-60 Hz. 
IP Rating	IPX1

* Purification capacity tested for raw water having TDS level of 750 ppm at room temperature.

Testing Information

The System has been tested according to IS 10500:2012 (Standards for drinking water as per Bureau of Indian Standards) for reduction of the hazardous substances.