

# KENT PRIME

FOR MOUNTING ON KITCHEN WALL

## KENT

Mineral RO™

Water Purifiers

HOUSE of PURITY

## Instruction Handbook for Installation, Operation and Maintenance.



### Mineral RO™ TECHNOLOGY

Removes Dissolved Impurities  
Retains Essential Minerals  
Multiple Purification

RO + UV + UF + TDS Control

*Kent Deta Hai*

**Sabse  
Shudh Paani**



## Welcome to KENT

Dear Customer,

At the outset, allow us to thank you for your trust in **KENT** water purifiers. We take pride in our reputation for product quality and industry proven performance. We are certain that your decision to own a **KENT Prime Mineral RO™** Water Purifier will go a long way towards keeping you and your family in good health. We are confident that you will be satisfied with its performance and that it will serve your need for safer and cleaner drinking water without any compromise.

This guide will help you in getting the best out of your water purifier. Please go through this booklet to familiarise yourself with its operation and maintenance.

You can look forward to years of trouble-free service. To ensure that the warranty of your water purifier is effective, it is important that you fill up the enclosed warranty card and mail us the installation report within 15 days of purchase. In case you need any further information, contact your nearest KENT dealer / branch.

Best Wishes,

**KENT RO SYSTEMS LTD.**

**KENT**

**Mineral RO™**

**Water Purifiers**

**HOUSE of PURITY**

## Table of Contents

1. KENT TECHNOLOGY - A Breakthrough in Water Purification	1
2. Salient Features	1
3. Items in the Box	1
4. Important Instructions	2
5. Reverse Osmosis Process	3
6. UV Process	3
7. Auto-flushing System	3
8. Water Flow Diagram	4
9. Electrical Circuit Diagram	4
10. UV Fail Alarm	5
11. Filter Change Alarm	5
12. Computer Controlled Operation	5
13. Automatic Operation	5
14. Installation Instructions	6
15. Recommended Use of Rejected Water	8
16. TDS Adjustment	9
17. Starting-up the Purifier	9
18. Maintenance	9
19. Important Safety Instructions	10
20. Warning	10
21. Technical Specifications	10
22. Testing information	11
23. Performance Data Sheet	11

## KENT TECHNOLOGY - A Breakthrough in Water Purification\*

Presenting the **KENT Prime Mineral RO™** Water Purifier; it uses futuristic and state-of-the-art technology to provide purer & healthier drinking water.

The heart of **KENT Prime Mineral RO™** Water Purifier is a Reverse Osmosis membrane having capillaries as small as 0.0001 microns that reduces even dissolved impurities (salts and heavy metals) and converts hard water to sweet and purer drinking water. **KENT Prime Mineral RO™** Water Purifier also allows the user to control the Total Dissolved Solids (TDS) level in purified water.

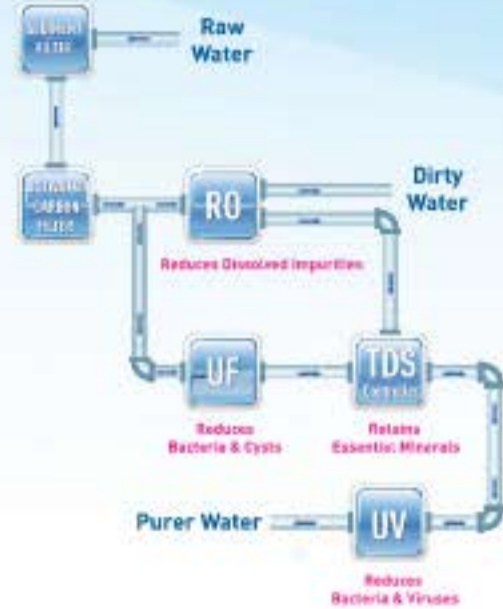

KENT is pleased to introduce Save Water Technology™ that helps you save and store water from KENT RO Purifiers as well as from other RO purifiers.

As a part of Save Water Technology, KENT introduces RO Reject Water Storage Tank, which can be purchased separately and then installed and connected to your KENT RO Purifier. This tank stores the rejected water from the purifier, which can be used for washing utensils and mopping the floor. This unique technology helps in high water recovery, thus reducing wastage.

### Salient Features of KENT Prime Mineral RO™ Water Purifier







- **Double treatment by RO + UV\* processes**
- High water recovery\*\*
- High Purification efficiency of 20 L/hr.
- Inbuilt auto flushing system
- Membrane with high flow
- Inbuilt TDS Controller that allows adjustment of TDS level of purified water
- Suitable for purification of Brackish / Tap Water / Municipal Corporation Water Supply.
- Wall mounted design; best suited for indian homes and offices
- 9L storage tank with water level indicator
- Fully automatic operation, with auto-on and auto-off function
- Computer controlled operations for enhanced purity and long life
- Filter Change Alarm\* to indicate filter replacement time
- UV Fail Alarm\* to indicate failure in UV system
- RO Membrane fused inside membrane housing to prevent tampering
- Vertically mounted SMPS for protection from water
- Use of push-fit fittings for leakage and maintenance free performance
- An eye appealing design
- ABS construction for corrosion free use

### Items in the Box

1. <b>KENT Prime Mineral RO™</b> Water Purifier	:	01 No.
2. 3-Way Connector	:	01 No.
3. S.S. Ball Valve	:	01 No.
4. Food Grade Pipe ¼ inch (White)	:	2.5 Meters
5. Food Grade Pipe ⅜ inch (White)	:	2.5 Meters
6. Instruction Manual	:	01 No.
7. Screws & Plastic Inserts	:	02 Nos. each
8. Sticker Center Drill	:	01 No.

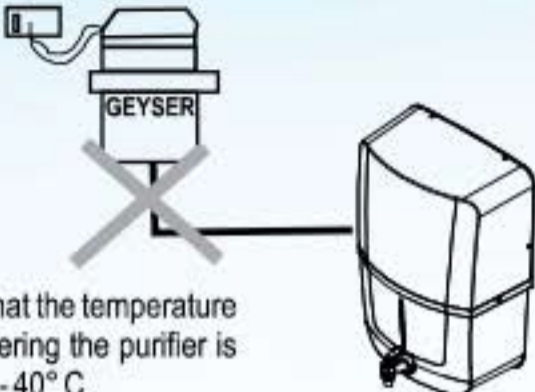
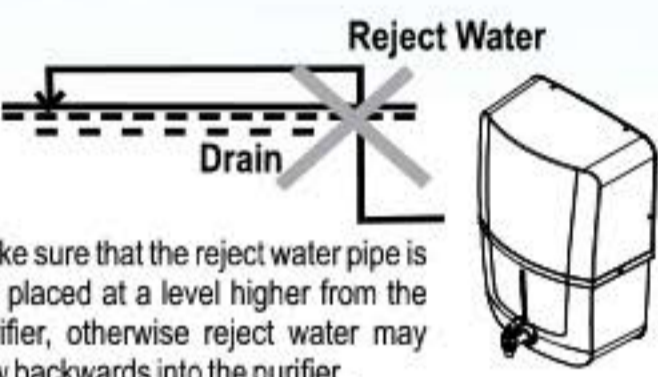
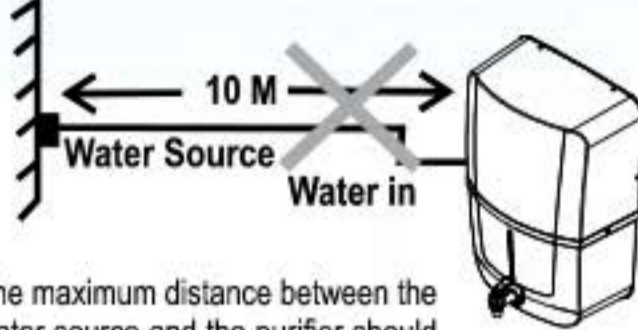
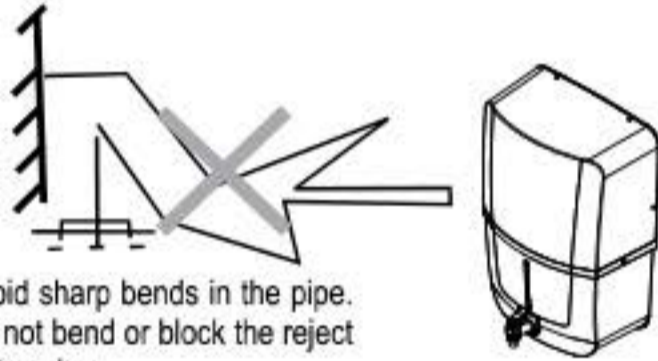
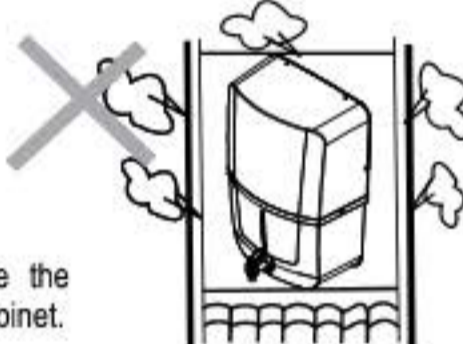
\*Tested & Certified by TUV-SUD South Asia (P) Ltd. \*\*High water recovery is based on the standard testing conditions.

## Important Instructions

 <p>Avoid exposure to direct sunlight and installation in damp areas.</p> 	 <p>Make sure that the temperature of water entering the purifier is within 10° C - 40° C</p>
 <p>Make sure that the reject water pipe is not placed at a level higher from the purifier, otherwise reject water may flow backwards into the purifier.</p>	 <p>The maximum distance between the water source and the purifier should not be more than 3 meters.</p>
 <p>Avoid sharp bends in the pipe. Do not bend or block the reject water pipe.</p>	 <p>Do not confine the purifier in a cabinet.</p>
 <p>In case of not using the purifier for more than two days, kindly switch off the power supply and drain the storage tank.</p>	<p>To keep the storage tank clean, it should be drained once in 15 days.</p> 
<p style="text-align: center;"><b>KENT</b></p> <p style="text-align: center;"><b>GENUINE</b> SPARE PARTS</p> <p>Use Genuine KENT spares for optimum performance.</p>	 <p>Do not try to service the purifier on your own. Instead, call service technician for help.</p> 

## Reverse Osmosis Process

The Reverse Osmosis process, also known as hyper filtration, is the finest filtration process known till date. The process ensures reduction of particles as small as ions from a solution. Reverse Osmosis uses a semi-permeable membrane to reduce salts from potable / brackish water. In Reverse Osmosis, water pressure applied to the concentrated side forces the process of osmosis into reverse. Under enough pressure, treated water is "squeezed" through the membrane from the concentrated side to the diluted side. Salts dissolved in water as charged ions are repelled by the RO membrane.

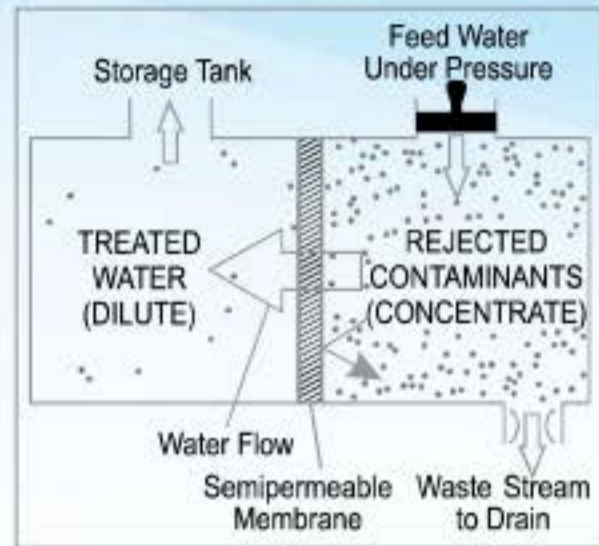

The rejected impurities on the concentrated side of the membrane are washed away in a stream of waste water and thus do not get accumulated as in a traditional filter.

## UV Process

The UV light has shorter wavelength (higher energy) than the visible light. It is called ultra-violet because it is just beyond violet light in the light spectrum. Technically, the ultra-violet light is defined to be any wavelength of light, which is shorter than 400 nanometer.

UV rays, which penetrate into the micro-organisms, are absorbed by the DNA of the pathogen in the water. The DNA is altered in such a way that the pathogen cannot reproduce itself. Thus, it is essentially killed and cannot cause infection. This process of DNA modification is called inactivation.

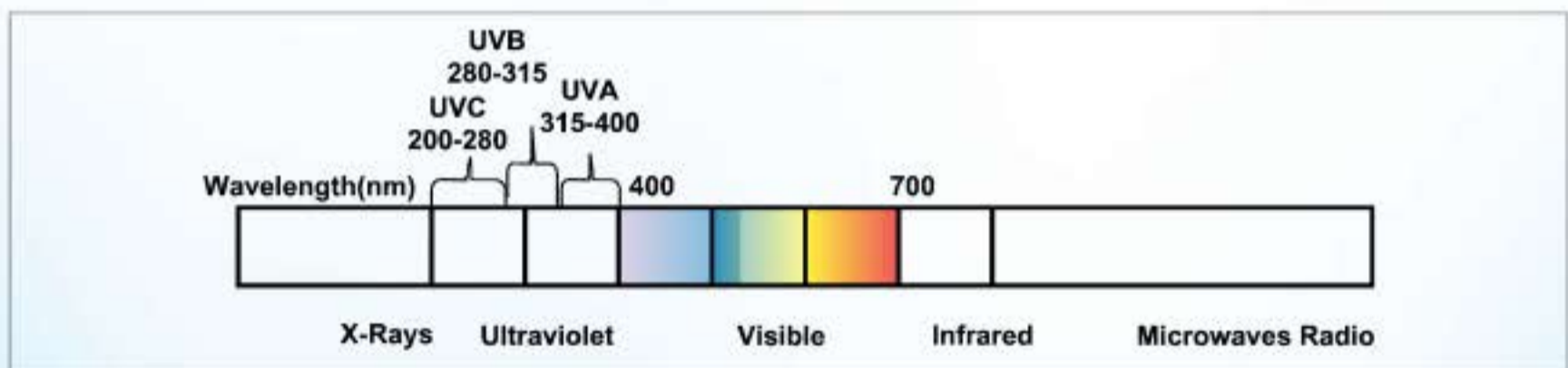

## Auto-flushing System

The purpose of the Auto-flushing system is to help prevent scaling or fouling of the RO membrane by providing a rapid rinse which washes away impurities from the membrane's surface and keeps the membrane clean. It offers following benefits.

- Lowers rejected water outflow
- Improves "TDS" rejection rate i.e increases RO membrane efficiency
- Extends life of RO membrane

## Water Flow Diagram

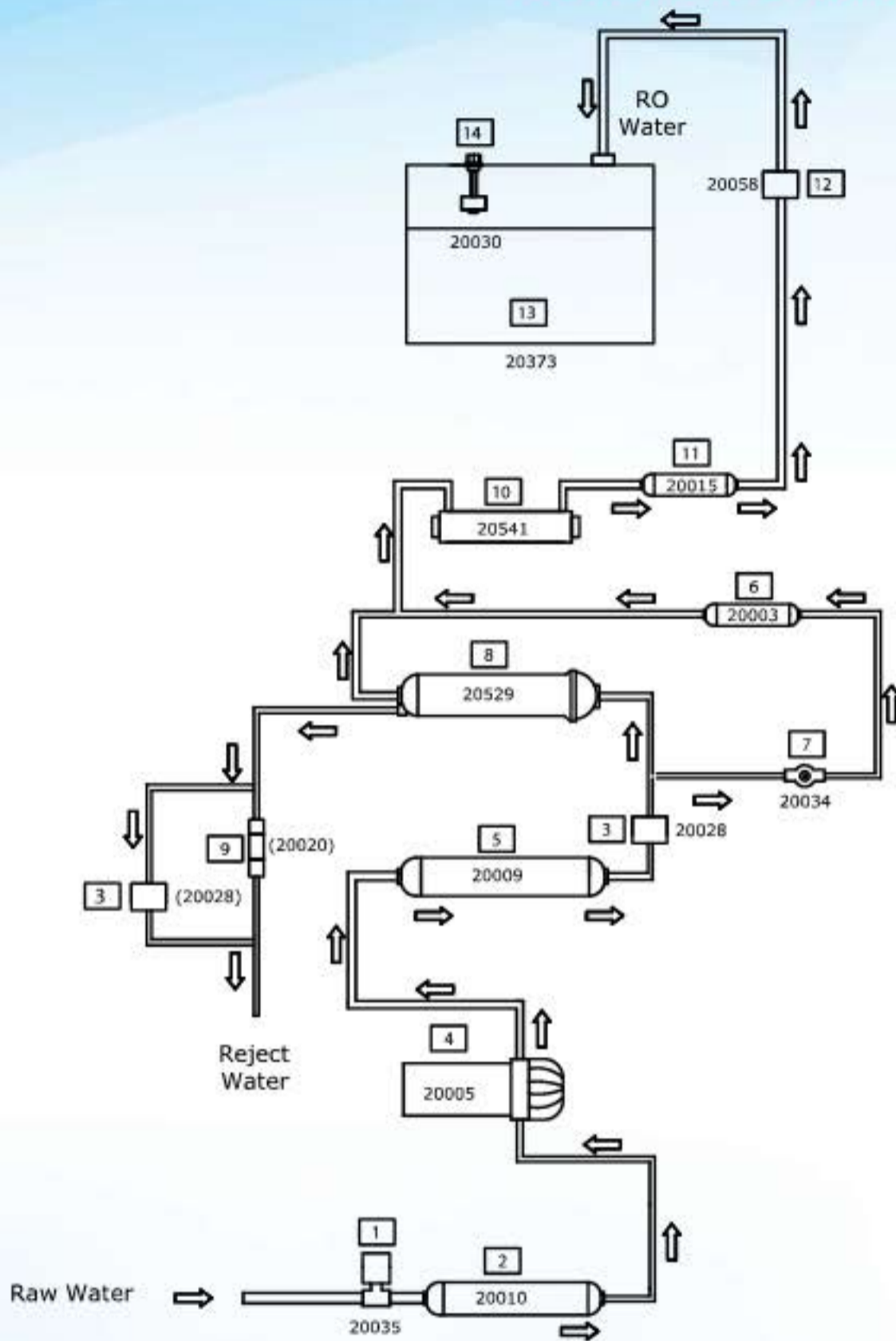

S.NO.	SP - CO.	ITEM DESCRIPTION
1	20035	LOW PRESSURE SWITCH
2	20010	SEDIMENT FILTER
3	20028	SOLENOID VALVE
4	20005	BOOSTER PUMP
5	20009	ACTIVATED CARBON FILTER
6	20003	UF FILTER
7	20034	TDS CONTROL VALVE
8	20529	RO MEMBRANE
9	20020	FLOW RESTRICTOR TUBE
10	20541	UV CHAMBER
11	20015	POST CARBON FILTER
12	20058	NON RETURN VALVE
13	20373	WATER STORAGE TANK
14	20030	FLOAT SENSOR

## Electrical Circuit Diagram

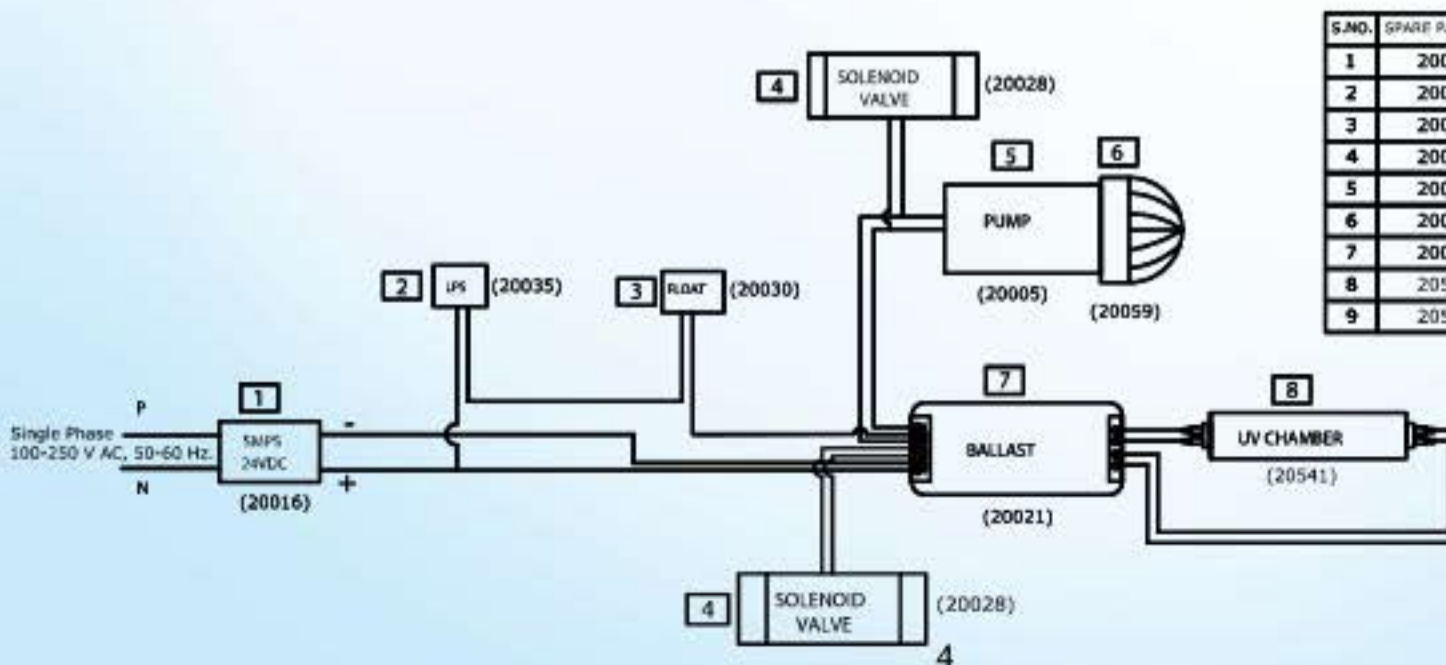

S.NO.	SPARE PART CODE	ITEM DESCRIPTION
1	20016	SMPS
2	20035	LOW PRESSURE SWITCH (LPS)
3	20030	FLOAT SENSOR
4	20028	SOLENOID VALVE
5	20005	BOOSTER PUMP
6	20059	PUMP HEAD
7	20021	BALLAST (CHOKE)
8	20541	UV CHAMBER
9	20540	UV LAMP

## UV Fail Alarm\*

**KENT Prime Mineral RO™** Water Purifier has an in-built feature that sounds an audible alarm if the UV lamp malfunctions. This feature is provided to ensure purity. This UV Fail Alarm will sound as follows:

Two short beeps after every two seconds.

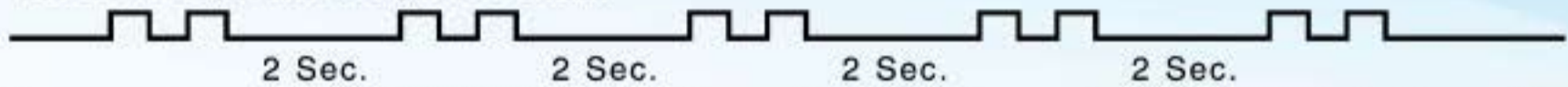

In case such an alarm is audible, kindly switch off the purifier and call the service technician for help. The purifier will stop its purification process in such a circumstance.

## Filter Change Alarm\*

**KENT Prime Mineral RO™** Water Purifier has an in-built feature that sounds an audible alarm to indicate replacement time for filters. This alarm will be audible after 700 hrs of use since the last filter change (or since the time of installation). The Filter Change Alarm will sound as follows:

4 short beeps after every two seconds; for 30 seconds. The alarm will repeat after every 2 hours of use.



In case such an alarm is audible, please call the service technician and request him to change the filters of the purifier. However, if the filters are not changed within the next 60 hours of operation, the purifier will stop functioning to ensure purity and hygiene. The following alarm will be audible after 60 Hrs. A continuous beep for an infinite time.



In case, such an alarm is audible, kindly switch off the purifier and call the service technician to replace the filters. In such a circumstance, the purifier will not function unless the filters are changed.

## Computer Controlled Operation\*

To ensure delivery of purer and healthier water, a micro-processor is installed in the purifier that performs the following functions:-

**UV Stabilization Delay:** To ensure that the UV lamp is pre-heated and is working at its optimum level before it starts disinfecting water, the controller provides a two seconds delay to UV lamp when the purifier is switched on. During this period, only the UV lamp is switched on and other electrical devices of the purifier are switched off.

**Purification Delay:** To ensure that the idle water lying in the internal pipes and in the UV chamber is disinfected before being passed into the storage tank, the system provides 5 second delay when the purifier is switched on. During this time, the UV lamp kills all micro-organisms that may be in the water inside UV chamber. After this delay, all other electrical devices such as booster pump and solenoid valve are switched on to start normal purification process.

**Audible Alarm:** The controller also controls the timing of UV Fail Alarm and the Filter Change Alarm.

## Automatic Operation

- The purifier automatically shuts off when the storage tank is full
- The purifier does not start when inlet water supply pressure falls below  $0.3 \text{ kg/cm}^2$
- The purifier automatically restarts when water level drops below the maximum
- The purifier does not allow any water rejection in absence of electricity / when tank is full

\* Tested & Certified by TUV-SUD South Asia (P) Ltd.



## Installation Instructions

The **KENT Prime Mineral RO™** Water Purifier is a product of advanced technology, which ensures safe and clean drinking water. The purifier is easy and convenient to install.

### Recommended Site Preparations:

- Single Phase 100-250 V AC, 50-60 Hz. connection not more than 3m away from the point of installation of purifier
- Raw water supply with ½ inch nipple not more than 3m away
- Drain for rejected water not more than 3m away
- Space as per dimensions of the purifier
- Wall/plane surface for mounting two screws and holding the machine
- The system and installation must comply with state and local laws and regulations

### Specific Instructions:

- **KENT Prime Mineral RO™** Water Purifier is a wall mountable purifier. Make sure that it is only mounted on a wall. Avoid installation on wooden and metallic stands
- For optimum performance and minimum inlet pressure required, ensure that the raw water supply tank is at least 10ft above the level at which the purifier is installed
- It is preferable to install the purifier near a sink so that inlet and reject water lines are easily available

### Installation Procedure:

#### Step-1

#### Wall Hanging Diagram

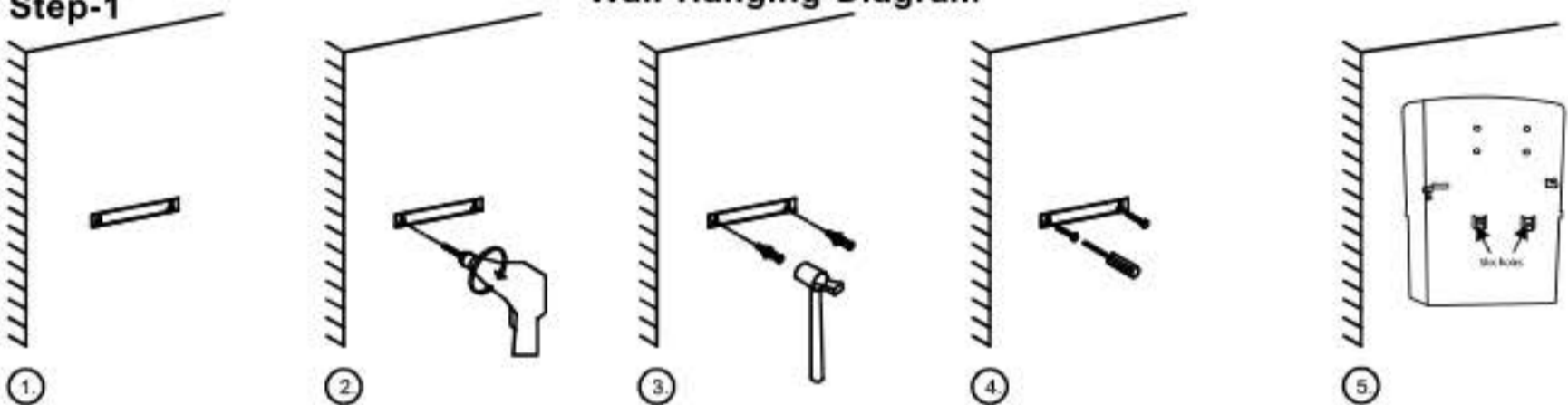

1. Paste the central drill sticker on wall at (3.6 Feet to 4.0 Feet from the ground) as per your convenience.
2. Ensure that sticker is pasted straight on the wall, then drill holes as per the space provided on sticker.
3. Now, insert the puff up with the help of a hammer.
4. Screw in two 10X50 self-taping screws, 5.4 inches (138 mm) apart horizontally.
5. Carefully hang the purifier on the wall with the help of wall-mounting slot holes provided on back side of the purifier.

#### Note:

1. If the wall is not straight or the screws are not properly drilled in an even position, it will damage your purifier.
2. Keep the device away from heat or direct sunlight.

#### Step-2

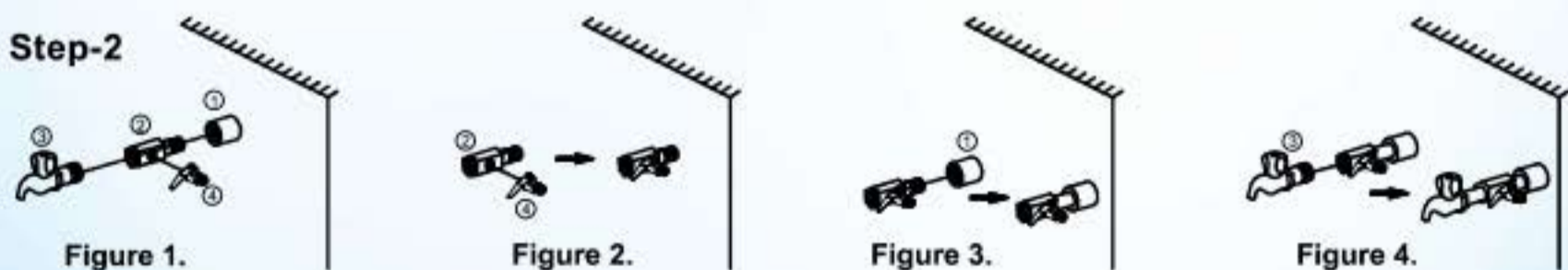

1. First fix the SS ball valve (marked as no. 4) to the 1/4 inch port of the 3-way connector (marked as no. 2) as shown in figure 2.
2. Connect the 3-way connector to the raw water supply (marked as no. 1) as shown in the figure 3. The 3-way connector is fitted in line with the raw water supply.
3. The other end of the 3-way connector can be connected to a tap (marked as no.3) as shown in figure 4. or can be plugged off if not required.

### Step-3

1. Now connect one end of the white pipe to SS ball valve and another end to the upper push-fit elbow fitting to the left hand side of the purifier labelled as WATER IN, as shown in fig 1.
2. Similarly, connect one end of the white pipe to the lower elbow fitting connector in tank labelled as REJECT WATER and leave the other end in the drain, as shown in fig 2.

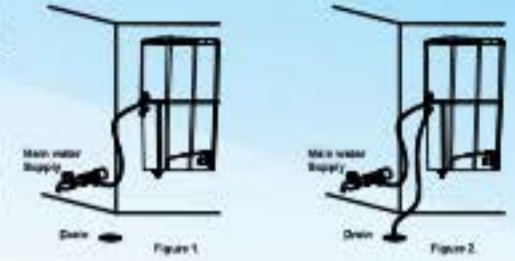

### Step-4

Before connecting the power supply, it is important that you perform the following functions:

1. Open the SS ball valve (Handle parallel to the ball valve) to start the flow of water into the purifier, as shown in the figure.
2. Wait for 2-3 minutes to ensure that the filters are soaked in water.

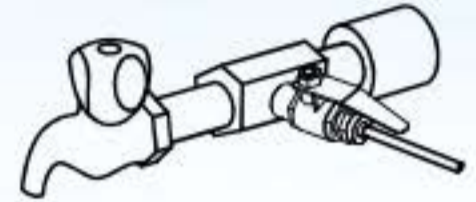

### Step-5

1. Connect the power supply.
2. Installation is complete.



## RO Reject Water Storage Tank (Optional Purchase)

The Ideal place for installation is above the sink as rejected water is ideally used for cleaning, utensils or mopping the floor. Every house has used utensils, which can be cleaned first with rejected water & subsequently with clean water. If you still have extra water left, we recommend you to use for mopping/ cleaning the floor.

## Installation Instructions

### A. Assembly of tank

<p><b>Step 01:</b> Open the box and take the storage tank out.</p>	
<p><b>Step 02:</b> Unscrew and remove the top cover.</p>	
<p><b>Step 03:</b> Using silicon washer, fix the tap on to the tank.</p>	
<p><b>Step 04:</b> Attach the fittings on to the holes provided on the side of the tank.</p>	
<p><b>Step 05:</b> Place the lid back and make sure it is placed properly.</p>	

<p><b>Step 06:</b> Screw the lid properly.</p>	
<p><b>Step 07:</b> The storage tank is ready for installation.</p>	

### B. Wall hanging procedure

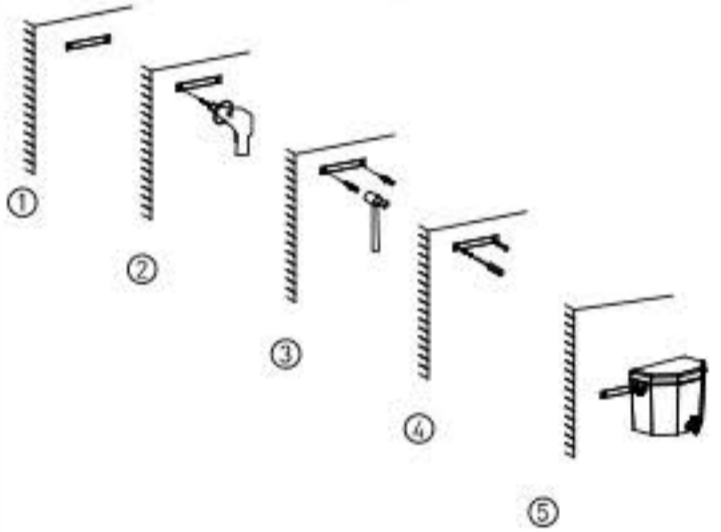
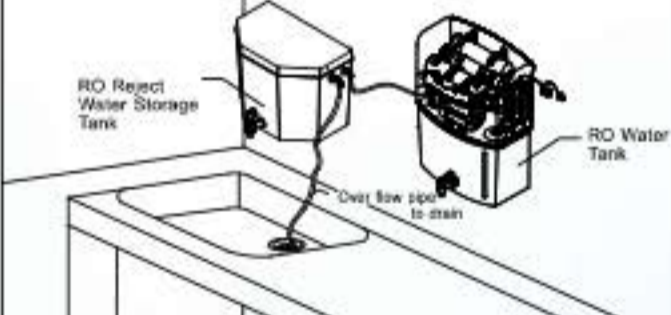
<p><b>Step 01:</b> Paste the center drill sticker on the wall preferably at 3.6 to 4 feet from the ground or as per convenience.</p> <p><b>Step 02:</b> Ensure that the sticker is pasted straight on the wall. Drill holes as per the markings provided on the sticker.</p> <p><b>Step 03:</b> Using a hammer, insert the puff-up in the wall.</p> <p><b>Step 04:</b> Screw two, '10 x 50' sized self-taping screws, 5.5 inches (140 mm) apart horizontally.</p> <p><b>Step 05:</b> Install the tank on wall using screws.</p>	
<p><b>Step 06:</b> Connect the pipes as shown in the image. Connect 1/4" reject water pipe from the RO to the smaller fitting and 3/8" pipe to the bigger fitting and put the open end into the drain.</p>	
<p><b>Installation is complete.</b></p>	

#### Note:

1. Keep the tank away from direct sunlight or heat.
2. If mounted on uneven wall surface or the screws are not properly drilled, it could damage the tank.

**Warning:** The water stored in RO Reject Water Storage Tank is not fit for drinking.

## Recommended Uses of Rejected Water

Although the rejected water has high concentration of salts, it is absolutely clean and free from impurities like chlorine, dirt, sand, etc. This rejected water usually goes down the drain but can be used for cleaning utensils & mopping the floor .

We recommend KENT RO Reject Water Storage Tank can be purchased separately to store & use RO reject water.

## TDS Adjustment\*

The unique TDS Control System enables customers to retain the contents of natural minerals (TDS) in purified water, as per their requirement.

- Turning the screw of the valve anti-clockwise, results in an increased mineral content.
- Turning the screw of the valve clockwise, results in a decreased mineral content.



We recommend keeping the TDS at lowest but not below 50mg/l.

## Starting-up the Purifier

- Switch on the power supply.
- Wait till the storage tank fully fills up\*\*.
- Switch off the power supply.
- Drain the storage tank by opening the drain plug present at the bottom of the storage tank so as to remove any dust particles present in the pipes and storage tank.
- Close the drain plug & switch on the power supply.
- The purifier is ready to use.

## Maintenance

To ensure that the purifier operates at its optimum level, a routine maintenance must be performed. The frequency of the maintenance will greatly depend upon the raw water quality and consumption of treated water

- Storage tank must be drained once in 2 weeks. To do so, switch off the power supply, open the drain plug at the bottom of the tank & allow the water to drain. Then screw back the plug and switch on the power supply.
- Replace sediment, activated carbon & post carbon when the filter change alarm is audible OR after every 12 months. It is recommended to change the FRT when the filters are replaced.
- Replace the RO membrane once in a year.
- Replace the UV Lamp once in a year.
- If you are not going to use the purifier for a long time ( in case you are on a holiday, tour or out of home), make sure that you disconnect the power supply, turn off the raw water supply and drain the storage tank.

Note: The reverse osmosis system contains a replaceable treatment component critical for the effective reduction of total dissolved solids and that product water shall be tested periodically to verify that the system is performing properly.

Replacement of spare parts are as under:-

-20010	SP	Inline Sediment Filter 8"
-20009	SP	Inline Carbon Filter 8"
-20529	SP	High Flow RO Membrane
-20015	SP	Post Carbon Filter (Blue)
-20003	SP	Hollow Fibre Membrane
-20020	SP	FRT 300/450

**Note:** Filters and membrane are consumables. Their replacement time is dependent on the quality of raw water and water consumption. They are not covered under the warranty. However, if a filter chokes within six months and a membrane within a year, it will be cleaned/repaired/replaced free of cost. Changing the filters and system inspection is available on call. The treatment capacity of RO membrane will reduce with time due to clogging of pores of membranes.

"This reverse osmosis system contains a replaceable component critical to the efficiency of the systems. Replacement of the reverse osmosis component should be with one of identical specifications as defined by the manufacturer, to ensure the same efficiency and contaminant reduction performance."

\* Tested & Certified by TUV-SUD South Asia (P) Ltd.

\*\* Tested or certified flushing time - 24hrs.

## Important Safety Instructions

- If the supply cord is damaged, it must be replaced by the original part in order to avoid hazard
- Children should be supervised to ensure that they do not play with the appliance
- This appliance is not intended for use by persons (including children) with reduced physical, sensory or mental capabilities, or lack of experience and knowledge, unless they have been given supervision or instruction concerning use of the appliance by a person responsible for their safety

## Warning

- Do not operate the UV-C emitter when it is removed from the appliance enclosure
- Read the maintenance instructions before opening the appliance
- The appliance must be disconnected from the supply before replacing the UV-C emitter

## Technical Specifications

PRODUCT	KENT PRIME
Product Code	11028
Product Generic Name	Water Purifier
Product Colour	White
Applications	Suitable for Purification of Brackish/Tap Water/ Municipal Corporation Water
Purification Production Rate	20 L/hr.*
Body Material	ABS Food Grade Plastic
Mounting	Wall-mounting
Dimensions (mm)	410 (L) x 260 (W) x 520 (H)
Inlet Water Pressure/Temp (Min.)	0.3 kg/cm <sup>2</sup> / 10°C
Inlet Water Pressure/Temp (Max.)	4 kg/cm <sup>2</sup> / 40°C
Min./Max. Operating pH	6.5 - 8.0
Filter Cartridge	Sediment, Carbon Block Filter, UF and Post Carbon
Auto-flushing System	Yes
UV Lamp Wattage	11 W
Life of UV Lamp	5000 hrs. of operation
Weight	8.34 kg
Storage Capacity	9 L
Maximum Duty Cycle	100 L/day
Membrane Type	Thin Film Composite RO
Booster Pump Voltage	24 V DC
Total Power Consumption	60 W
Input Power Supply	Single Phase 100-250 V AC, 50-60 Hz. 
IPX Number	IPX1

\* Treatment capacity tested for tap water having TDS level of 750 ppm at room temperature.

## Testing Information

The System has been tested according to IS 10500:2012 (Standards for drinking water as per Bureau of Indian Standards) for reduction of the hazardous substances as listed below.

### Performance Data Sheet-KENT Prime Mineral RO™ Water Purifier

This system has been tested according to NSF/ANSI 58 for reduction of the substances listed below. The concentration of the indicated substances in water entering the system was reduced to a concentration less than or equal to the permissible limit for water leaving the system, as specified in NSF/ANSI 58.

Substance	Influent challenge concentration mg/L	Maximum permissible product water concentration mg/L	Minimum % reduction
Total Dissolved Solids	750 ± 40 mg/L	187	86.8%
Arsenic (+5)	0.30 ± 10%	0.010	98.7
Barium	10.0 ± 10%	2.0	97.7
Fluoride	8.0 ± 10%	1.5	96.3
Lead	0.15 ± 10%	0.010	99.3
Nitrate / Nitrite	30 ± 10%	10	68.5

Do not use with water that is microbiologically unsafe or of unknown quality w/o adequate disinfection before or after the system.

Efficiency rating means the percentage of the influent water that is available to the user as reverse osmosis treated water under operating condition that approximate typical daily usage.



Arsenic, Barium, Fluoride, Lead, Nitrate/Nitrite contents as tested & certified by WQA as per standards NSF/ANSI 58.

The system conform to NSF/ANSI 58 for the specific performance claims as verified and substantiated by test data. While testing was performed under standard laboratory conditions, actual performance may vary.

The influent water to the system shall include no organic solvents, Chlorine <2 mg/L, pH 7-8, Iron <2mg/L, Turbidity <1 NTU and hardness <1000mg/L.

"This system is acceptable for treatment of influent concentrations of no more than 27 mg/L Nitrate and 3 mg/L Nitrite (in combination measured as N), and is certified for nitrate/nitrite reduction only for water supplies with pressure of 140 kpa ( 20 psi) or greater."

This system has been tested for the treatment of water containing pentavalent arsenic (also known as As (V), As (+5), or arsenate) at concentrations of 0.30 mg/L or less. This system reduces pentavalent arsenic but may not remove other forms of arsenic. This system is to be used on water supplies containing detectable free chlorine residual or on water supplies that have been demonstrated to contain only pentavalent arsenic. Treatment with chloramines (combined chlorine) is not sufficient to ensure complete conversion of trivalent arsenic to pentavalent arsenic. Please see the Arsenic Facts section of the performance data sheet for further information.

## Arsenic Facts

Arsenic (As) is a naturally occurring contaminant found in many ground waters. It generally occurs in two forms (valences or oxidation states): pentavalent arsenic (also known as As(V), As(+5), or arsenate) and trivalent arsenic (also known as As(III), As(+3), or arsenite). In natural ground water, arsenic may exist as trivalent arsenic, pentavalent arsenic, or a combination of both. Although both forms of arsenic are potentially harmful to human health, trivalent arsenic is considered more harmful than pentavalent arsenic. More information about arsenic and its toxicity can be found on the U.S. Environmental Protection Agency website at <http://www.epa.gov/safewater/arsenic.html>.

This system is designed to remove only pentavalent arsenic. This treatment system does not provide a feature for conversion of trivalent arsenic to pentavalent arsenic. The system may remove some trivalent arsenic, however, it has not been evaluated for its ability to remove trivalent arsenic.

Trivalent arsenic is generally more difficult to remove from drinking water than pentavalent arsenic. Trivalent arsenic can be converted to pentavalent arsenic in the presence of an effective oxidant such as free chlorine. The arsenic in water containing detectable free chlorine or that has been treated with another effective oxidant will be in the pentavalent arsenic form.<sup>4</sup> Treatment with chloramine (combined chlorine) is not sufficient to ensure complete conversion of trivalent arsenic to pentavalent arsenic.

Consumers using public water supplies can contact their utility to verify whether free chlorine treatment chemicals are being used. Private water supplies and waters that do not have detectable free chlorine residuals should be analyzed to determine the form(s) of arsenic present and the potential need for oxidation of trivalent arsenic to pentavalent arsenic.

Arsenic does not generally impart color, taste, or smell to water, therefore, it can only be detected by a chemical analytical test. Public water supplies are required to monitor treated water for total arsenic (trivalent arsenic plus pentavalent arsenic) and the results are available to the public from the utility. Consumers using private water sources will need to make arrangements for testing. A total arsenic test usually costs about \$15-\$30 and it is recommended the test be conducted by a certified laboratory. Local health departments or environmental protection agencies can help provide consumers with a list of certified laboratories. Some laboratories may also be able to analyze specifically for (speciate) the form(s) of arsenic present in a water sample if requested.

This treatment system was tested under laboratory conditions as defined in NSF/ANSI 58 Drinking Water Treatment Units – Health Effects and was found to reduce 0.30 mg/L of pentavalent arsenic in the test water to less than 0.010 mg/L under standard testing conditions. Actual performance of the system may vary depending on specific water quality conditions at the consumer's installation. Following installation of this system, the consumer should have the treated water tested for total arsenic to verify arsenic reduction is being achieved and the system is functioning properly.

The arsenic removal component of this system must be replaced at the end of its useful life of 1-2 years. The replacement component, 20010 SP Inline Sediment Filter 8", 20009 SP Inline Carbon Filter 8", 20002 SP RO Membrane Welded 8" Housing, 20015 SP Post Carbon Filter (Blue), 20003 SP Hollow Fibre Membrane (RO), 20018 SP FRT 550/600 can be purchased directly from the manufacturer Kent RO Systems Ltd.

**KENT**  
*Mineral RO™*  
Water Purifiers  
**HOUSE of PURITY**



\*To request for service 24x7,  
download KENT Service App  
by scanning  
the QR code  
or by giving  
a missed call:  
9212252852



To speak to customer care executive call: 92-789-12345



Marketed by:  
KENT RO SYSTEMS LTD.  
E-6, 7 & 8, Sector-59, Noida, U.P.-201 309, India.  
E-mail: sales@kent.co.in | Website: www.kent.co.in

Manufactured by:  
KENT RO SYSTEMS LTD.  
1) Khasra No. 93, Village-Bantakhedi, Tehsil-Roorkee,  
District-Haridwar, Uttarakhand-247 668, India.  
2) A-6, Sector-87, Noida-201 305, U.P., India.

For customer complaints, contact our Customer Care Officer at:  
E-6, 7 & 8, Sector-59, Noida, U.P.-201 309, India. Call: 92-789-12345  
E-mail: service@kent.co.in or visit us at www.kent.co.in