

KENT ACE LITE

FOR MOUNTING ON KITCHEN WALL

KENT

Mineral RO™

Water Purifiers

HOUSE of PURITY

KENT

Mineral RO™
Water Purifiers

HOUSE of PURITY



Marketed by:
KENT RO SYSTEMS LTD.
E-6, 7 & 8, Sector-59, Noida, U.P.-201 309, India.
E-mail: sales@kent.co.in | Website: www.kent.co.in

Manufactured by:
KENT RO SYSTEMS LTD.
1) Khasra No. 93, Village-Bantakhedi, Tehsil-Roorkee,
District-Haridwar, Uttarakhand-247 668, India.
2) A-6, Sector-87, Noida-201 305, U.P., India.

For customer complaints, contact our Customer Care Officer at:
E-6, 7 & 8, Sector -59, Noida, U.P.-201 309, India. Call: 92-789-12345
E-mail: service@kent.co.in or visit us at www.kent.co.in

Instruction Handbook for Installation, Operation and Maintenance



Kent Deta Hai
**Sabse
Shudh Paani**

KENT TECHNOLOGY
Removes Dissolved Impurities
Retains Essential Minerals
Multiple Purification
RO + UF + TDS Control

Reverse Osmosis Water Purifier with Ultra-Filtration Process & TDS Controller
Mineral RO © 2005 - KENT RO SYSTEMS LTD., the process & purifier is patented vide patent no. 199716.
KENT ACE LITE design is registered vide registration no. 260986

Welcome
to KENT

Dear Customer

Welcome to the world of **KENT**, leaders of the water purification industry in India. With a **KENT** product you have all the reasons to smile, since at **KENT** we take pride in the quality and laboratory-tested performance of our products.

We are confident that your decision to own, **ACE LITE Mineral RO™** will go a long way in serving you with purer and mineral enriched drinking water, thus keeping you and your family in good health. We assure you, that you will be satisfied with its trouble-free performance and quality which come without any compromise.

This manual is an effort towards familiarizing you with the operation and of your maintenance of your **KENT ACE LITE Mineral RO™**. Before operating the unit, please read the manual thoroughly and retain it for future reference. To ensure that the warranty of your water purifier is effective please fill up the enclosed warranty card and send the installation report within 15 days of purchase. Should you need further assistance, do not hesitate to contact your nearest **KENT** dealer or branch.

Best wishes

KENT RO SYSTEMS LTD.

Table of Contents

1. KENT TECHNOLOGY - A Breakthrough in Water Purification	1
2. Salient Features of KENT ACE LITE Mineral RO™	1
3. Items in the Box	1
4. Important Instructions	2
5. Reverse Osmosis Process	3
6. UF Process	3
7. Water Flow Diagram	4
8. Electrical Circuit Diagram	4
9. Automatic Operation	5
10. Installation Instructions	5
11. TDS Adjustment	6
12. Starting Up the Purifier	7
13. Recommended Usage of Rejected Water	7
14. Maintenance	7
15. Important Safety Instructions	8
16. Technical Specifications	9
17. Testing Information	9

KENT TECHNOLOGY A Breakthrough in Water Purification*

KENT proudly presents **KENT ACE LITE MINERAL RO™** - its new and advanced domestic water purifier which provides purer & healthier drinking water.

The futuristic **KENT ACE LITE**, developed at **KENT** laboratory, broadly comprises of a state-of-the-art RO+UF+TDS Control System. The initial purification by RO membrane with porosity as fine as 0.0001 microns reduces even dissolved impurities (hard salts, heavy metals etc.). Double purification by UF membrane gives additional protection from deadly harmful micro-organisms. Moreover, the patented TDS Control System intelligently retains essential natural minerals in the purified water, thus, taking total care of your health and wellbeing.



Salient Features of KENT ACE LITE Mineral RO™













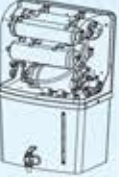
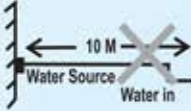

- Wall mounted design - best suited for domestic purpose.
- Compact design - needs lesser space for installation.
- Double purification by RO+UF process.
- TDS Control System* allows adjustment of TDS level of purified water.
- 8 L storage capacity.
- Storage tank with water level indicator.
- Vertically mounted SMPS for protection.
- RO and UF Membranes fused inside membrane housing to prevent tampering.
- Push-fit components for leak-proof & maintenance-free performance.
- Fully automatic operation with auto-on and auto-off function.
- ABS construction for corrosion-free life span.
- Suitable for purification of brackish/ tap water/Municipal water supply.

Items in the Box

- | | |
|---|---------------|
| 1. KENT ACE Lite Mineral RO™ Water Purifier | : 1 No. |
| 2. 3-Way Connector | : 1 No. |
| 3. S.S. Ball Valve | : 1 No. |
| 4. Food Grade Pipe ¼ inch (White) | : 2.5 m |
| 5. Food Grade Pipe ⅜ inch (White) | : 2.5 m |
| 6. Screws & Plastic Inserts | : 2 Nos. each |
| 7. Sticker Center Drill | : 1 No. |
| 8. Warranty Card | : 1 No. |

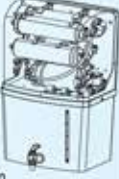
* Tested & certified by TUV-SUD South Asia (P) Ltd.

Important Instructions

 <p>Avoid exposure to direct sunlight and installation in damp areas.</p> 	 <p>Make sure that the temperature of the water entering the purifier is between 10-40° C.</p> 
 <p>Make sure that the reject water pipe is not placed at a level higher than the system, otherwise it may flow backwards into the purifier.</p> 	 <p>Maximum distance between the water source and the purifier should not be more than 3 meters.</p> 
 <p>Avoid sharp bends in the pipe fittings. Do not bend or block the reject water pipe.</p> 	 <p>Do not confine the purifier in a cabinet.</p>
 <p>In case of not using the purifier for more than two days, kindly switch off the power supply and drain the storage tank.</p> 	 <p>To keep the storage tank clean, it should be drained once in 15 days.</p>
 <p>Always use genuine KENT spares for optimum performance.</p>	 <p>Do not try to service the purifier on your own. Instead, call service a technician for help.</p> 

Reverse Osmosis Process

The Reverse Osmosis process, also known as hyper filtration, is the finest filtration process known till date. The process ensures the reduction of particles as small as ions from a solution. The Reverse Osmosis process uses a semi-permeable membrane to reduce salts from potable/brackish water. In Reverse Osmosis, water pressure is applied to the impure water inlet resulting in the squeezing of purer water from concentrated end of the membrane towards the diluted end. Dissolved salts present in the water in the form of charged ions get repelled by the RO membrane and are not allowed to pass through. Similarly, bacteria and germs are also blocked by the ultra fine pores of the RO membrane. These rejected impurities, suspended on the concentrated end of the membrane, are then washed away as a stream of waste water, thus preventing the membrane from clogging.

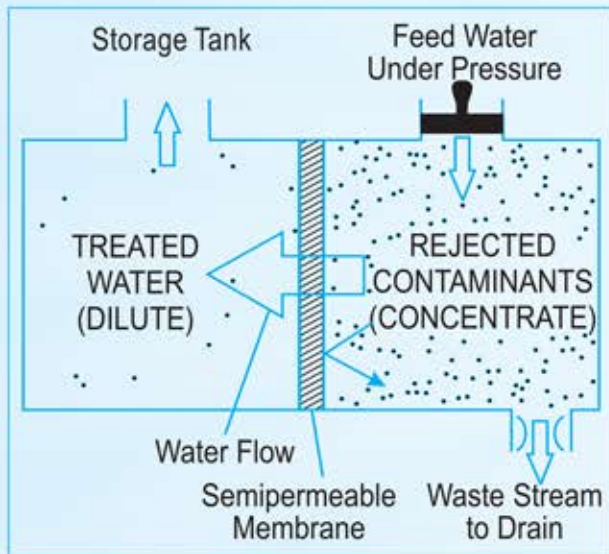

UF Process

Ultra Filtration is a separation process that uses membranes with pore size in the range of 0.1 to 0.01 micron. UF membrane removes high molecular-weight substances, colloidal materials and organic/inorganic polymeric molecules including bacteria and viruses. Low applied pressure is therefore sufficient to achieve high flux rates from an Ultra Filtration membrane.

Water Flow Diagram

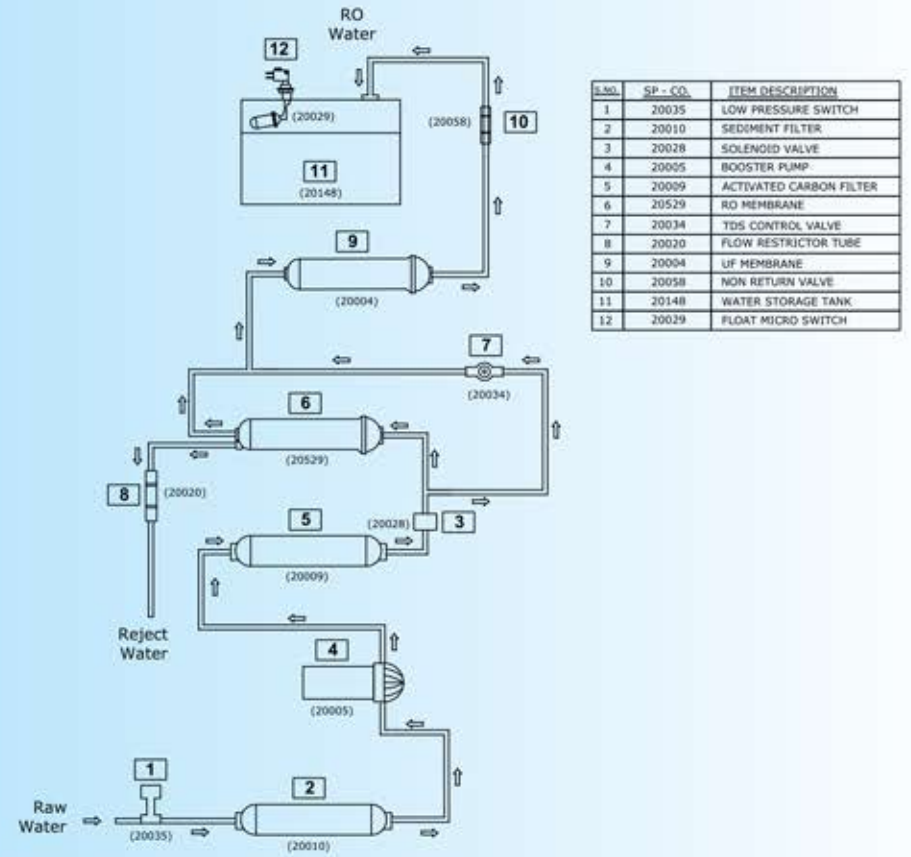

S.NO.	SP - CO.	ITEM DESCRIPTION
1	20035	LOW PRESSURE SWITCH
2	20010	SEDIMENT FILTER
3	20028	SOLENOID VALVE
4	20005	BOOSTER PUMP
5	20009	ACTIVATED CARBON FILTER
6	20529	RO MEMBRANE
7	20034	TDS CONTROL VALVE
8	20020	FLOW RESTRICTOR TUBE
9	20004	UF MEMBRANE
10	20058	NON RETURN VALVE
11	20148	WATER STORAGE TANK
12	20029	FLOAT MICRO SWITCH

Electrical Circuit Diagram

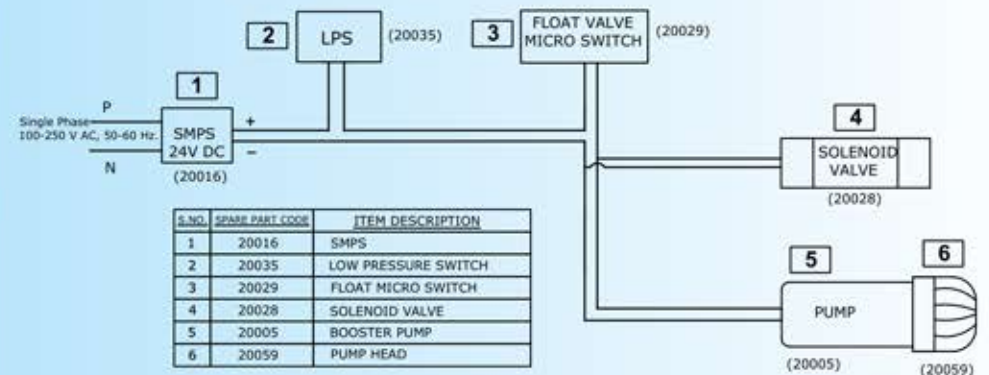

S.NO.	SPARE PART CODE	ITEM DESCRIPTION
1	20016	SMPS
2	20035	LOW PRESSURE SWITCH
3	20029	FLOAT MICRO SWITCH
4	20028	SOLENOID VALVE
5	20005	BOOSTER PUMP
6	20059	PUMP HEAD

Automatic Operation

- The purifier automatically shuts off when the storage tank is full.
- The purifier does not start if the inlet water supply pressure drops below 0.3 kg/cm².
- The purifier automatically restarts when the water level drops below the maximum.
- The purifier does not allow any water rejection in absence of electricity/when the tank is full.

Installation Instructions

KENT ACE LITE Mineral RO™ is a convenient and easy-to-install wall mounting model.

Recommended Site Preparations:

- Single Phase 100 – 250 V AC, 50-60 Hz not more than 3m away from the point of installation.
- Raw water supply with ½ inch nipple not more than 3m away.
- Drain for the reject water not more than 3m away.
- Installation space as per the dimensions of the purifier.
- Wall/plane surface for mounting screws and holding the machine. Avoid installation on wooden and metallic stands.
- For optimum inlet pressure the source water tank should be at least 10 ft. above the purifier installed.
- Install the purifier near a sink for easy availability of inlet and reject water lines.
- The system and installation must comply with state and local laws and regulations.

Installation Procedure

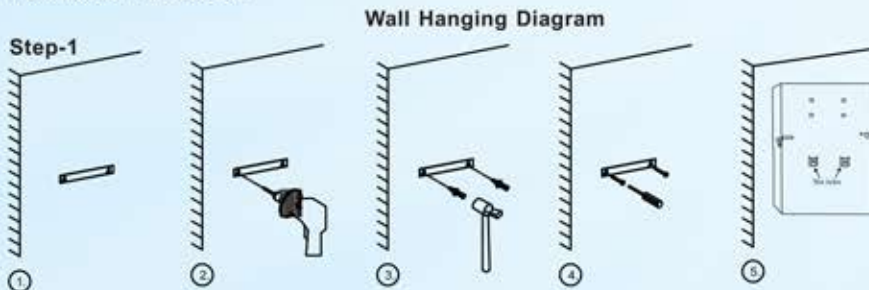

1. Paste the central drill sticker on the wall at (3.6 feet to 4.0 feet from the ground) as per your convenience.
2. Ensure that sticker is pasted straight on the wall, then drill holes as per the space provided on the sticker.
3. Now, insert the puff up with the help of a hammer.
4. Screw in two 10X50 self-taping screws, 5.4 inches (138 mm) apart horizontally.
5. Carefully hang the purifier on the wall with the help of the wall-mounting slot holes provided on the back of the purifier.

Note: If the wall is not straight or the screws are not properly drilled in an even position, it will damage your purifier.

Note: Keep the device away from heat or direct sunlight.



1. First fix the SS ball valve (marked as no. 4) to the ¼ inch port of the 3-way connector (marked as no.2) as shown in Figure 2.
2. Connect the 3-way connector to the raw water supply (marked as no. 1) as shown in Figure 3. The 3-way connector is fitted in line with the raw water supply.
3. The other end of the 3-way connector can be connected to a tap (marked as no.3) as shown in Figure 4. or can be plugged off if not required.

Step-3

1. Now connect one end of the white pipe to the SS ball valve and another end to the upper push-fit elbow fitting to the left hand side of the purifier labelled as WATER IN, as shown in fig 1.
2. Similarly, connect one end of the white pipe to the lower elbow fitting connector in tank labelled as REJECT WATER and leave the other end in the overhead tank, as shown in fig 2.

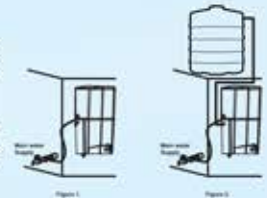

Step-4

Before connecting the power supply, it is important that you perform the following functions:

1. Open the SS ball valve (handle parallel to the ball valve) to start the flow of water into the purifier, as shown in the figure.
2. Wait for 2-3 minutes to ensure that the filters are soaked in water.

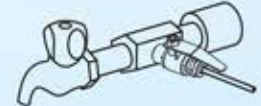

Step-5

Connect the power supply.

Installation is complete.

TDS Adjustment*

The unique TDS Control System enables customers to retain the contents of natural minerals (TDS) in the purified water, as per their requirement.

- Turning the screw of the valve anti-clockwise, results in increased mineral content.
- Turning the screw of the valve clockwise, results in decreased mineral content.



We recommend keeping the TDS at lowest possible level but not below 50mg/l.

Starting Up the Purifier

- Switch on the power supply.
- Allow the storage tank to fill to its maximum capacity.**
- Switch off the power supply.
- Open the drain plug present at the bottom of the storage tank and drain the tank completely. This would remove the residual dust particles present in different pipes and storage tank.
- Plug back the drain plug.
- Switch on the power supply.
- The purifier is now ready to use.

Recommended Usage of Rejected Water

Although the rejected water has high concentration of salts, it is absolutely clean and free from impurities such as chlorine, dirt, sand, etc. This rejected water usually goes down the drain but can be used for gardening purposes. The high concentration of salts and minerals accelerates the plant growth. Rejected water can also be used for cleaning utensils, mopping etc.

Maintenance

To ensure that the purifier operates at its BEST, routine maintenance must be performed. Frequency of the maintenance will greatly depend upon the raw water quality and consumption of purified water.

- The storage tank must be drained once in 2 weeks. Open the drain plug present at the bottom of the storage tank and drain the tank completely. Plug back the drain plug and switch on the power supply.
- Replace the sediment filter & activated carbon filter once in 12 months. It is recommended to change the FRT along with the filters.
- Replace the RO membrane once in a year.
- Replace the UF membrane once in a year.
- In the event of not using purifier for a long time (while going for a holiday, tour etc.), make sure that you disconnect the power supply, turn off the raw water supply and drain the storage tank.

 The replacement time of consumables such as filters and membrane is dependant on the quality of raw water and the quantity of purified water consumed.

 Use genuine Kent spares for optimum performance.

Note: The reverse osmosis system contains a replaceable treatment component critical for the effective reduction of total dissolved solids and that product water shall be tested periodically to verify that the system is performing properly.

* Tested & certified by TUV-SUD South Asia (P) Ltd.

** Tested & certified flushing time - 24hrs.

Replacement of spare parts are as under:-

-20010	SP Inline Sediment Filter 8"
-20009	SP Inline Carbon Filter 8"
-20529	SP RO Membrane
-20004	SP UF Membrane Welded 8" Housing
-20020	SP FRT 300/450

"This reverse osmosis system contains a replaceable component critical to the efficiency of the system. Replacement of the reverse osmosis component should be with one of identical specifications as defined by the manufacturer, to ensure the same efficiency and contaminant reduction performance."

Important Safety Instructions

- If the supply cord is damaged, it must be replaced by the original part in order to avoid hazard
- Children should be supervised to ensure that they do not play with the appliance
- This appliance is not intended for use by persons (including children) with reduced physical, sensory or mental capabilities, or lack of experience and knowledge, unless they have been given supervision or instruction concerning use of the appliance by a person responsible for their safety

Technical Specifications

Product	ACE LITE
Product Code	11105
Product Color	White
Applications	Suitable for purification of brackish/tap water/ Municipal Corporation water.
Purification Production Rate	20 L/hr.
Body Material	ABS Food Grade Plastic
Mounting	Wall Mounted
Dimensions(mm)	380 (L) x 270 (W) x 505 (H)
Inlet Water Pressure/Temp (Min.)	0.3 kg/cm ² /10°C
Inlet Water Pressure/Temp (Max.)	4 kg/cm ² /40°C
Min./Max. Operating pH	6.5 - 8
Filter Cartridge	Sediment, Activated Carbon, UF Filter
Membrane Type	Thin Film Composite RO
UF Membrane	0.1 – 0.01 Micron
Net Weight	7.35 kg
Storage Capacity	8 L
Maximum Duty Cycle	100 L/day
UF Filter	Ultra Filtration Membrane
Booster Pump Voltage	24V DC
Total Power Consumption	60 W
Input Power Supply	Single Phase 100 – 250 V AC, 50-60 Hz 
IP Rating	IPX1

* Purification capacity tested on raw water having TDS level of 750 ppm at room temperature.

Testing Information

The System has been tested according to IS 10500:2012 (Standards for drinking water as per Bureau of Indian Standards) for reduction of the hazardous substances.